



NORTH SHORE BILLET

PRODUCT: TALON CRANKS

ASSEMBLY: STEP 1 – CRANKS OUT OF BOX

TOOLS NEEDED: NSB BB TOOL OR EQUIVALENT (PARK TOOL BBT-79)
8MM ALLEN KEY, 2.5MM ALLEN KEY, TORQUE WRENCH, GREASE

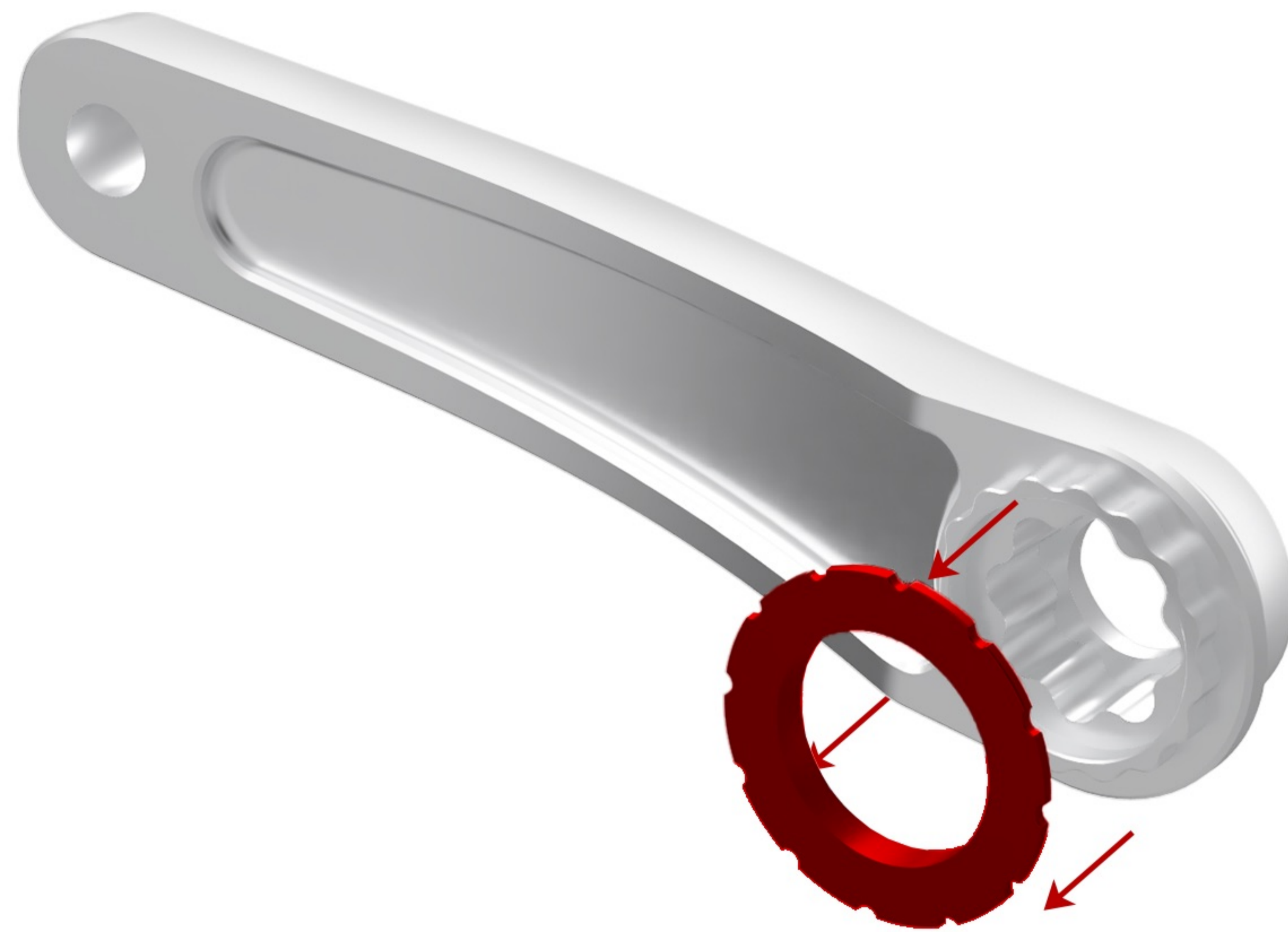

NORTH SHORE BILLET
PRODUCT: TALON CRANKS
ASSEMBLY: STEP 2 – DRIVESIDE CRANK

REMOVE CHAINRING NUT FROM CRANK



NORTH SHORE BILLET

PRODUCT: *TALON CRANKS*

ASSEMBLY: *STEP 2.1 – DRIVESIDE CRANK*

SECURE CHAINRING TO CRANK WITH THE CHAINRING NUT – HAND TIGHTEN



NORTH SHORE BILLET

PRODUCT: *TALON CRANKS*

ASSEMBLY: *STEP 2.2 – DRIVESIDE CRANK*

*TIGHTEN CHAINRING SECURING NUT TO 30NM
USING THE NSB BOTTOM BRACKET TOOL OR EQUIVALENT (EG: PARK TOOL BBT-79)*

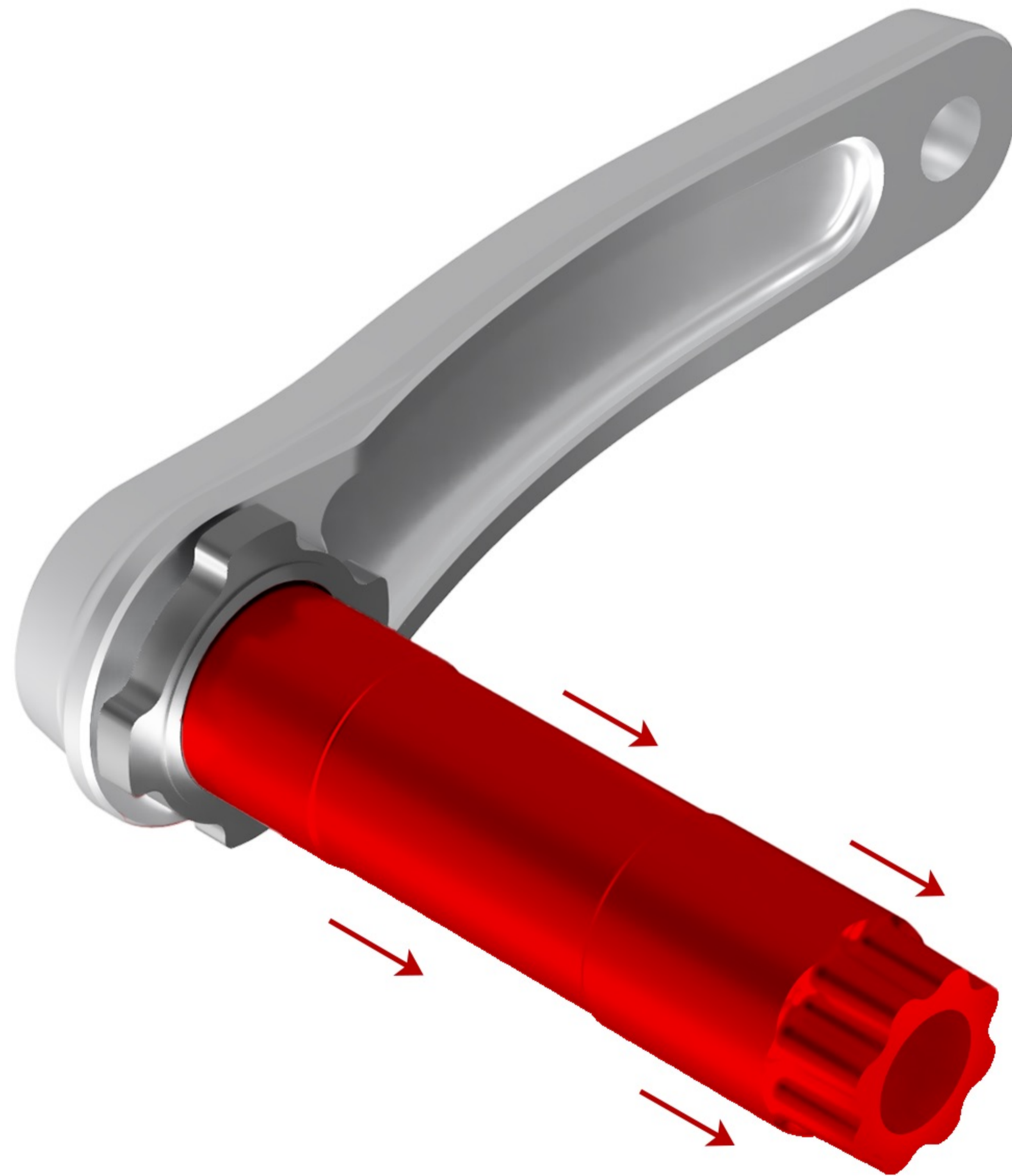

NORTH SHORE BILLET

PRODUCT: TALON CRANKS

ASSEMBLY: STEP 3 – NON-DRIVESIDE CRANK

SLIDE SPINDLE THROUGH BOTTOM BRACKET UNTIL FULLY INSERTED



NORTH SHORE BILLET

PRODUCT: TALON CRANKS

ASSEMBLY: STEP 4 – DRIVESIDE CRANK

ALIGN DRIVE SIDE CRANK WITH SPINDLE
BEGIN TO TIGHTEN 8MM BOLT UNTIL IT CATCHES THREADS IN THE SPINDLE

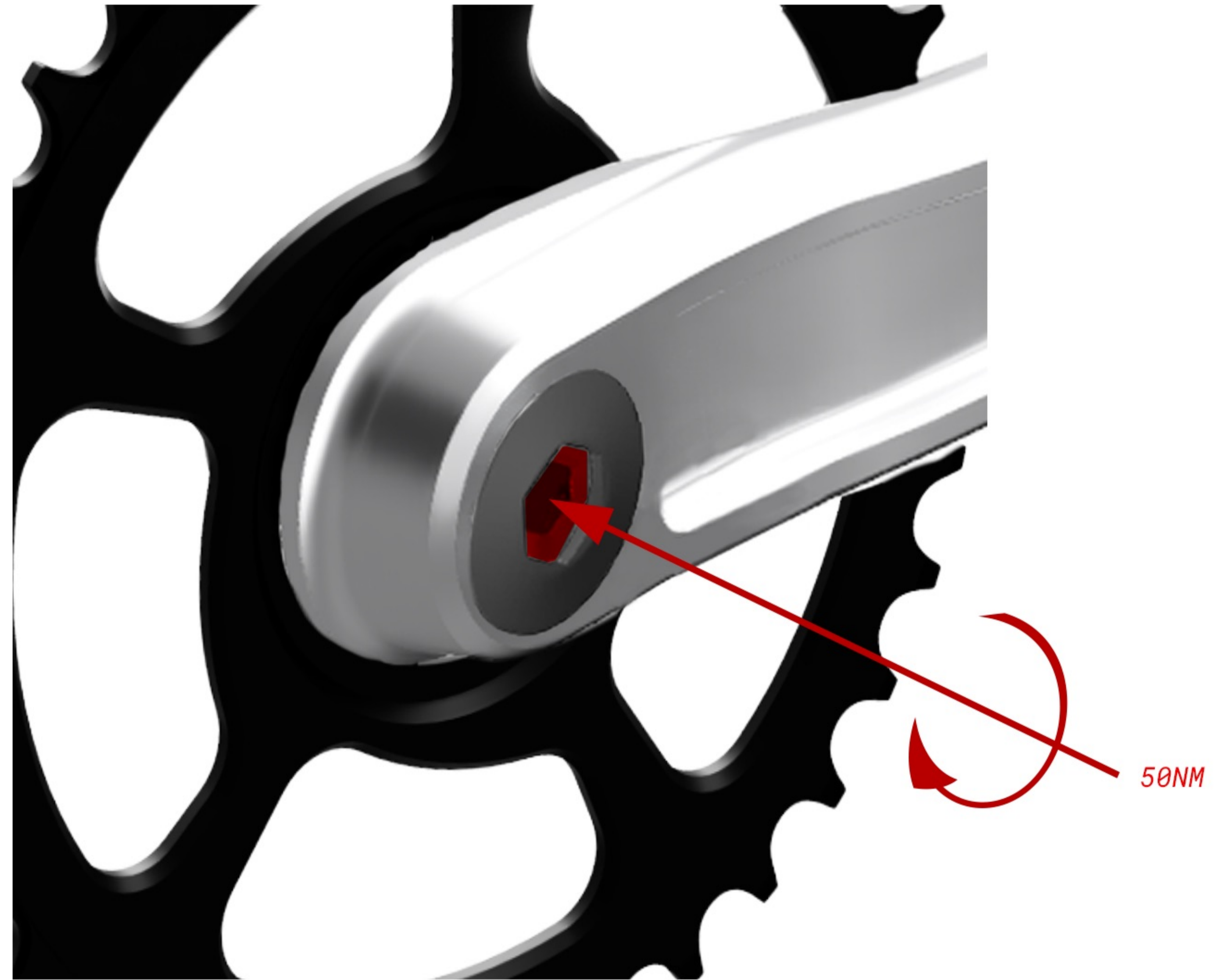

NORTH SHORE BILLET

PRODUCT: *TALON CRANKS*

ASSEMBLY: *STEP 4.1 – DRIVESIDE CRANK*

TIGHTEN 8MM BOLT AND TORQUE TO 50NM



NORTH SHORE BILLET

PRODUCT: TALON CRANKS

ASSEMBLY: STEP 5 – NON-DRIVESIDE CRANK

HAND TIGHTEN THE ALLOY PRE-LOAD NUT. CHECK CRANK ASSEMBLY IS FIRMLY IN PLACE, SPINNING FREELY WITH NO SIDE-TO-SIDE PLAY

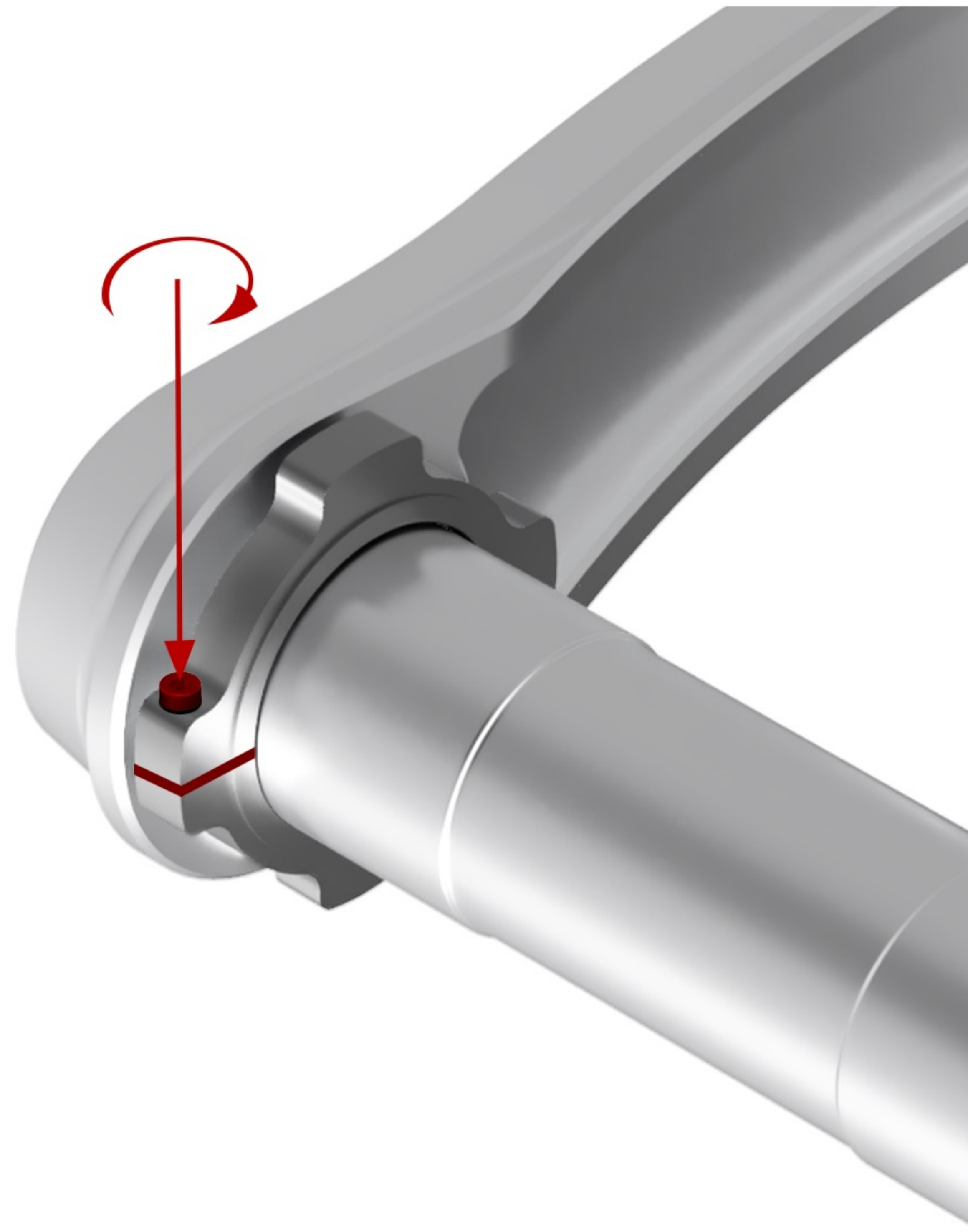

NORTH SHORE BILLET

PRODUCT: *TALON CRANKS*

ASSEMBLY: *STEP 5.1 – NON-DRIVESIDE CRANK*

WITH A 2.5MM ALLEN-KEY, TIGHTEN PRE-LOADER PINCH-BOLT TO 1NM